

Rick Bronson's HOUSE OF COMEDY

Hors d'oeuvres

R• SAMPLER

wings, zesty shrimp, cheddar cheese curds, sweet potato fries, homemade french fries & onion strings ~ 25 ³/₄

CHEESE CURDS

real wisconsin white cheddar cheese curds, fried with a crispy coating. served with ranch dressing for dipping ~ 7

R• WINGS

hot, salt & pepper or chili-lime ~ 8 ¹/₂

ZESTY SHRIMP

breaded shrimp tossed in a creamy, spicy glaze ~ 8

FRIED OLIVES & PICKLES

green olives lightly dusted & fried, accompanied with fried crispy kosher dills ~ 6

POUTINE

crispy fresh cut fries covered with wisconsin cheddar cheese curds & smothered in warm gravy ~ 7 ³/₄

FRIES

hand-cut french fries ~ 3 ¹/₂
sweet potato fries ~ 4

ONION STRINGS

crispy fried onion strings ~ 3 ³/₄

FRI-TRIO

sweet potato fries, onion strings and hand-cut french fries ~ 9 ¹/₂

Salads

CHOPPED COBB

iceberg, chicken, avocado, blue cheese, bacon, black olives, tomato, egg, choice of dressing ~ 9

TRADITIONAL CAESAR

romaine, bacon, croutons, parmesan & asiago cheese ~ 7

compliment your caesar with your choice of the following:

chicken (traditional or blackened) +2
salmon filet or rock shrimp +3

Burgers

R•blend

ground brisket, sirloin & chuck seasoned & aged

R•sauce

it's a secret you'll want all to yourself

KOBE BURGER

¹/₂ pound of 100% kobe beef burger, topped with caramelized onions, smoked bacon, cheddar cheese and crispy onion strings. complimented with roasted garlic aioli ~ 10 ³/₄

BLUE LUCY BURGER

our unique R•blend patty, stuffed with bleu cheese, topped with smoked bacon & served with R•sauce ~ 8 ³/₄

CLASSIC CHEESEBURGER

our signature R•blend ¹/₂ pound patty, topped with melted cheddar cheese, served with lettuce, tomato, onion & R•sauce ~ 8

GRILLED CHICKEN BURGER

all natural chicken breast, avocado, applewood bacon, swiss cheese & garlic aioli mayo ~ 8 ¹/₂

GARDEN BURGER

black bean vegetable patty, melted mozzarella, swiss & garlic aioli mayo ~ 8

burgers are cooked to medium well, unless otherwise requested

the state requires us to advise you that eating undercooked foods may be harmful

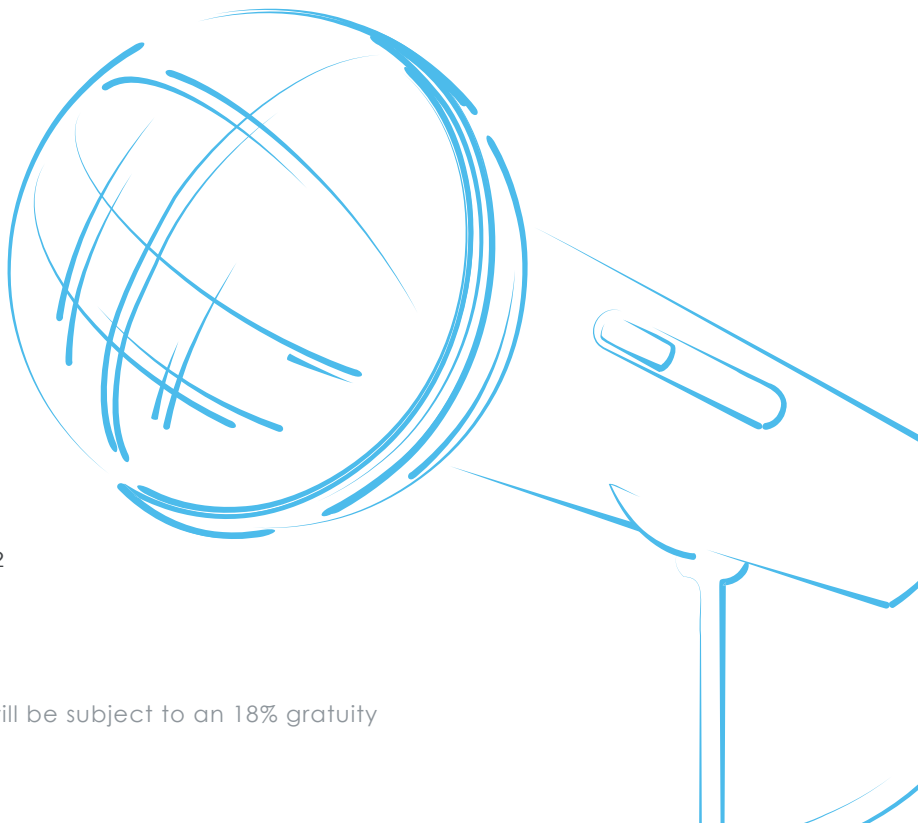

Rick Bronson's HOUSE OF COMEDY

Dinner Entrées

entrées are complimented with our signature 3-cheese potatoes au gratin and seasonal vegetable, excluding pasta dishes which are served with a warm garlic breadstick

GRILLED CHOICE RIBEYE

available in 12oz or 16oz cut ~ 19, 24

suggested wine 🍷 terrazas malbec

CHICKEN BRUSCHETTA

grilled chicken topped with our homemade tomato, onion & basil bruschetta ~ 18

SALMON FILETS

drizzled with a basil-butter sauce ~ 20

suggested wine 🍷 frei brothers chardonnay

BACON-WRAPPED PORK MEDALLIONS

topped with fresh mango salsa ~ 19

CHICKEN PARMIGIANA

crispy chicken breast & melted mozzarella on a bed of linguini with classic marinara sauce ~ 17

suggested wine 🍷 rosemount shiraz

BROCCOLI LINGUINI ALFREDO

crisp broccoli and linguini tossed in creamy alfredo sauce ~ 15

compliment your pasta with your choice of the following:

chicken (traditional or blackened) +2
salmon filet or rock shrimp +3

suggested wine 🍷 ecco domani pinot grigio

add a side garden or caesar salad ~ 3, 3 ½

add our featured dessert selection ~ 3 ½

add both ~ 5

{ Group Events

inquire about our in-house catering menu for large groups, business meetings, special events & more }

groups of 8+ will be subject to an 18% gratuity